

Thermal Overload relays



Thermal overload relays

Type TA
Class 10

2

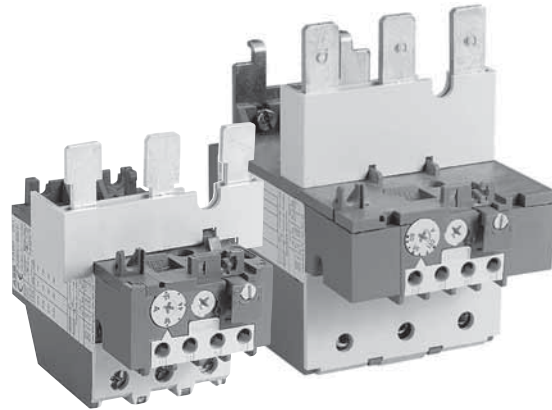

Description

- Available for starter construction with A Line contactors and separate panel mounting
- Designed for close couple mounting
- Separate base mounting available for all overload relays
- Class 10 adjustable overload relays are standard with all ABB Line starters
- Reset can also be adjusted to function as a stop button
- Screwdriver guide holes
- All terminal screws are available from the front
- UL File No: E48139
- CSA File No: LR98336
- Trip indication
- Remote trip and reset option available
- Single phase and phase unbalance protection
- Isolated alarm circuit (N.O.) contact
- Ambient compensation: -25°C to +55°C (-13°F to +131°F)
- Manual test
- Manual or automatic reset
- Factory calibrated and tested
- Wide adjustment range

Tripping classes of the thermal overload relays

Standard classes in IEC 947-4-1 are classes: 10 A, 10, 20, 30. The tripping class indicates according to IEC 947-4-1 the maximum tripping time in seconds under specified conditions of test at 7.2 times the setting current and specifies tripping and non tripping times for 1.5 and 7.2 times the setting current. Mostly used class is 10 A.

Abstract from IEC 947-4-1

Tripping class	10 A	10	20	30
Max. tripping time at 1.5 x setting current (warm state) (s)	120	240	480	720
Tripping time at 7.2 x setting current (cold state) (s)	2 – 10	4 – 10	6 – 20	9 – 30
At 1.05 x setting current	no tripping			

TA thermal overload relays are used with A Line contactors for the protection of motors having a nominal voltage of up to 600VAC max per UL/CSA (690VAC and 800VDC per IEC).

Product range

• Standard relays:

Types: TA25DU, TA42DU, TA75DU, TA80DU, TA110DU, TA200DU and TA450DU

- TA25 to TA110 and TA200 are directly connected in the motor circuit.
- TA450DU relays are fed through a linear type transformer

• Special construction

Thermal overload relays with different certifications and approvals.
Relays for protection EEx e motors.

Construction and function

• General

Thermal O/L relays and their accessories meet UL, CSA and most other important international standards (IEC), European standards (EN) and the most important national standards (DIN-VDE, NFC-UTE, BS, etc.). They meet the certification and approval directives required throughout the world.

Thermal overload relays are 3 pole. The motor current flows through their bimetals (1 per phase) which are indirectly heated. Under the effect of the heating, the bimetals bend, cause the relay to trip and the position of the auxiliary contacts to change.

The relay setting range is graduated in amps. In compliance with international and national standards, the setting current is the motor nominal current and not the tripping current (no tripping at 1.05 x setting current, tripping at 1.2 times setting current).

The tripping curves (cold or warm starting, 3 phases and 2 phases) are shown on page 2.14.

The relays are built to be self protecting in the event of an overload until the short circuit protection device is activated.

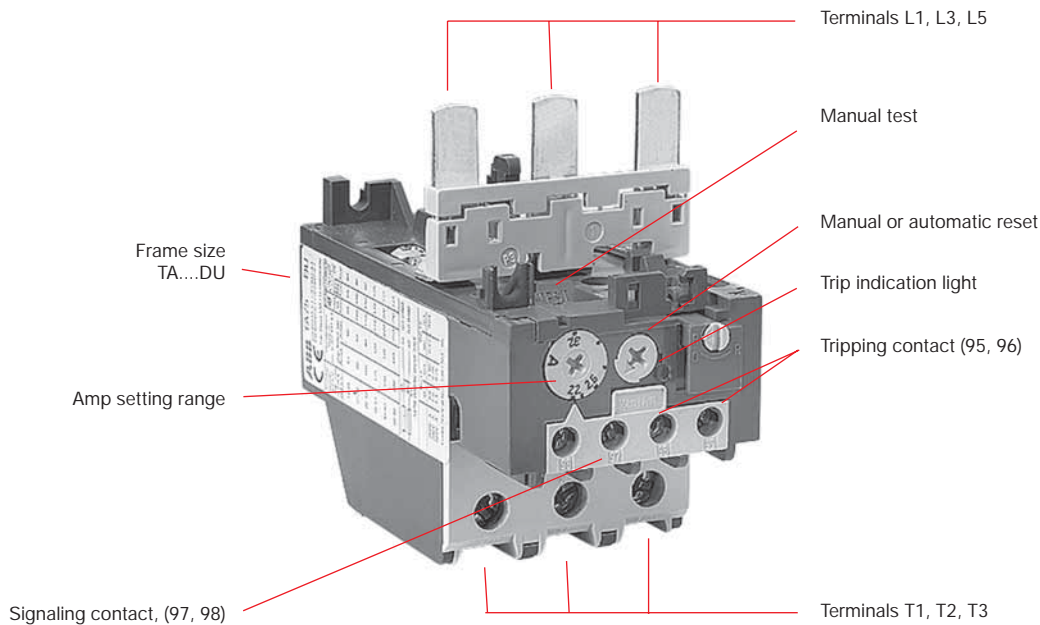

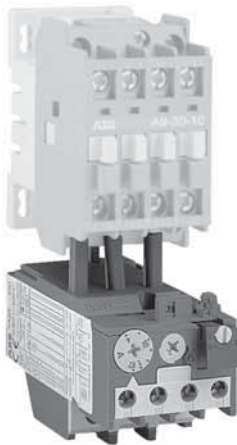

TA25DU

Application

Technical data

• All the relays have:

- Free tripping: the resetting button, even if held in, does not prevent tripping of the thermal overload relay in the event of a fault.
- Temperature compensation
- Phase failure protection according to IEC 947-4-1: Within the limits of the setting range, a reduced tripping time, and thus improved motor protection, is obtained in case of a phase failure.
- Tripping class: 10A, for TA relays
- Test functions and resetting: see table below.

• Auxiliary contacts

The relays have two built in auxiliary contacts: NC marked 95-96; NO marked 97-98. Both contacts are physically separate and can thus be used for 2 different circuits (control circuit and indication circuit).

Function of TA25DU – TA450DU thermal O/L relays

	Resetting Contacts	Relay tripped		Relay not tripped Both manual and automatic
		Manual	Automatic	
Effect of blue button indexed on R (RESET ONLY)	Resetting	Yes	No	No
	95-96	Closed when the button is pressed	No effect	No effect
	97-98	Open when the button is pressed		
Effect of blue button indexed on R/O (RESET/OFF)	Resetting	Yes	No	No
	95-96	Closed when the button is released	No effect	Open when the button is pressed Closed when the button is released
	97-98	Open when the button is pressed		