

S280UC

500 VDC

Supplemental protectors

K UL 1077 VDE 0660
CSA 22.2 No. 235
Cable and Equipment Protection



S281UC-K, 1 pole



S282UC-K, 2 pole

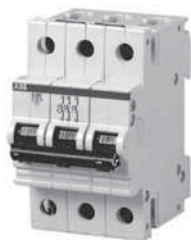

S283UC-K, 3 pole

Rated current	Catalog number	List price	Delivery class	Sugg. order qty	Wgt. oz. (1 pc.)
1 pole					
0.2	S281UC-K0.2	\$ 104			
0.3	S281UC-K0.3	104			
0.5	S281UC-K0.5	104			
0.75	S281UC-K0.75	104			
1	S281UC-K1	104			
1.6	S281UC-K1.6	104			
2	S281UC-K2	104			
3	S281UC-K3	104			
4	S281UC-K4	104			
6	S281UC-K6	104	B	10	4.6
8	S281UC-K8	104			
10	S281UC-K10	104			
16	S281UC-K16	104			
20	S281UC-K20	104			
25	S281UC-K25	108			
32	S281UC-K32	110			
40	S281UC-K40	116			
50	S281UC-K50	136			
63	S281UC-K63	152			

Rated current	Catalog number	List price	Delivery class	Sugg. order qty	Wgt. oz. (1 pc.)
2 pole					
0.2	S282UC-K0.2	242			
0.3	S282UC-K0.3	242			
0.5	S282UC-K0.5	242			
0.75	S282UC-K0.75	242			
1	S282UC-K1	242			
1.6	S282UC-K1.6	242			
2	S282UC-K2	242			
3	S282UC-K3	242			
4	S282UC-K4	242	B	5	9.2
6	S282UC-K6	242			
8	S282UC-K8	242			
10	S282UC-K10	242			
16	S282UC-K16	242			
20	S282UC-K20	242			
25	S282UC-K25	248			
32	S282UC-K32	256			
40	S282UC-K40	266			
50	S282UC-K50	312			
63	S282UC-K63	348			

Rated current	Catalog number	List price	Delivery class	Sugg. order qty	Wgt. oz. (1 pc.)
3 pole					
0.2	S283UC-K0.2	\$ 370			
0.3	S283UC-K0.3	370			
0.5	S283UC-K0.5	370			
0.75	S283UC-K0.75	370			
1	S283UC-K1	370			
1.6	S283UC-K1.6	370			
2	S283UC-K2	370			
3	S283UC-K3	370			
4	S283UC-K4	370	B	3	13.9
6	S283UC-K6	370			
8	S283UC-K8	370			
10	S283UC-K10	370			
16	S283UC-K16	370			
20	S283UC-K20	370			
25	S283UC-K25	382			
32	S283UC-K32	408			
40	S283UC-K40	448			
50	S283UC-K50	472			
63	S283UC-K63	534			

Delivery Class

- A - Standard item, stock to 2 weeks lead time
- B - Stock to 4 weeks lead time
- C - 6 to 8 week lead time

Direct current applications

The S280UC differs from standard miniature circuit breakers in that the UC versions include a permanent magnet which aids in the extinguishing of the arc during medium and high level faults. It is necessary to observe the correct polarity and current direction when connecting the UC breakers. Two examples of correct connection are shown below.

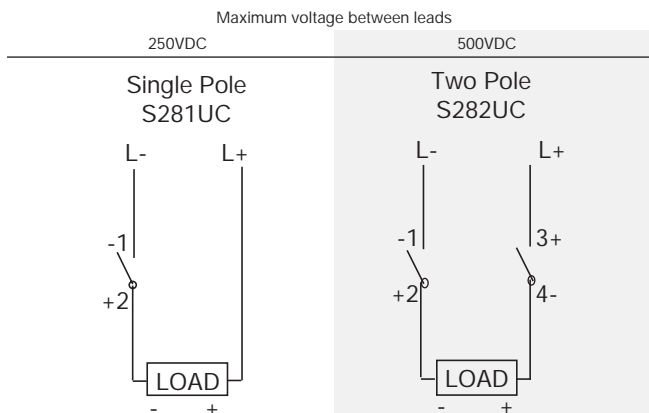
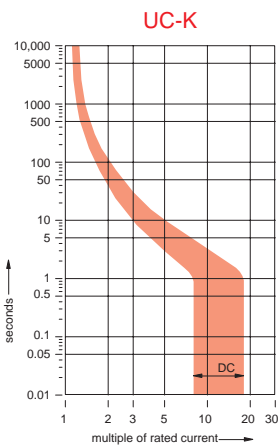

Termination points are marked on all UC type MCBs, points one (1) and four (4) are negative and points two (2) and three (3) are positive. Four pole breakers are also available for voltage reversal applications.